

# GENUINE Illuminated Door Scuff Plates

## INSTALLATION INSTRUCTIONS



Thank you for purchasing a Genuine Mazda Accessory.

Before removal and installation, **Please thoroughly read these instructions.**

For your safety, please read the contents of this booklet to properly install and use the wireless charger.

Keep these instructions with your vehicle records for future reference.



- There are several  **WARNING** and  **CAUTION** sections in this booklet concerning safety when installing or removing Mazda Genuine Accessories. Always read and follow the instructions in order to prevent injuries, accidents, and possible damages.

 **WARNING** : Indicates a situation in which serious injury or death could result if the warning is ignored.

 **CAUTION** : Indicates a situation in which bodily injury or damage to the vehicle could result if the caution is ignored

- For areas indicating the tightening torque in this instruction manual, tighten to the specified torque by using a torque wrench. For areas in which the tightening torque is indicated inside parentheses ( ), the tightening torque is indicated as a reference value, however tightening using a torque wrench is not necessary.
- Do not modify the Illuminated Scuff Plate.
- Do not install the Illuminated Scuff Plate in any way other than described in the following instructions.
- If in doubt, please contact your Mazda dealer to install the accessory in order to prevent errors in installation.
- If you have any questions about the use of the accessory, ask your Mazda dealer for proper advice before using it.
- Mazda and its suppliers are not responsible for injuries, accidents, and damage to persons and property that arise from the failure of the dealer or installer to follow these instructions.
- To ensure safety and reliability of the work, installation, removal and disposal work must be carried out by an Authorized Mazda Dealership.
- Be careful not to lose removed parts, and be sure that they are kept free of dirt, scratches, or damage.









<b>PART NAME:</b>	<b>Illuminated Door Scuff Plates</b>
<b>PART NUMBER:</b>	<b>KMV6V1370 / KMS6V1370</b>
<b>VEHICLE:</b>	<b>MAZDA CX-90</b>

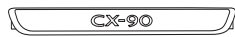

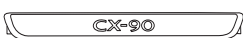
# 1. PARTS

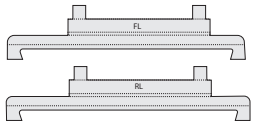
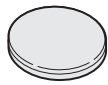
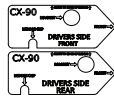
**NOTE**

- Verify that the kit includes all the following parts and that the parts are not dirty, scratched, or damaged.

Part	Part name	Qty	Part	Part name	Qty
	Front Illuminated Scuff Plate	2		O-Ring	4
	Rear Illuminated Scuff Plate	2		Battery CR 2430	4
	Installation Template Front and Rear Driver and Passenger	4		Magnet	4
	Magnet Locating Templates	4		Magnet Tape	4
	Battery Cap	4		Alcohol Pads	4

# 2. INSTALLATION VIEW

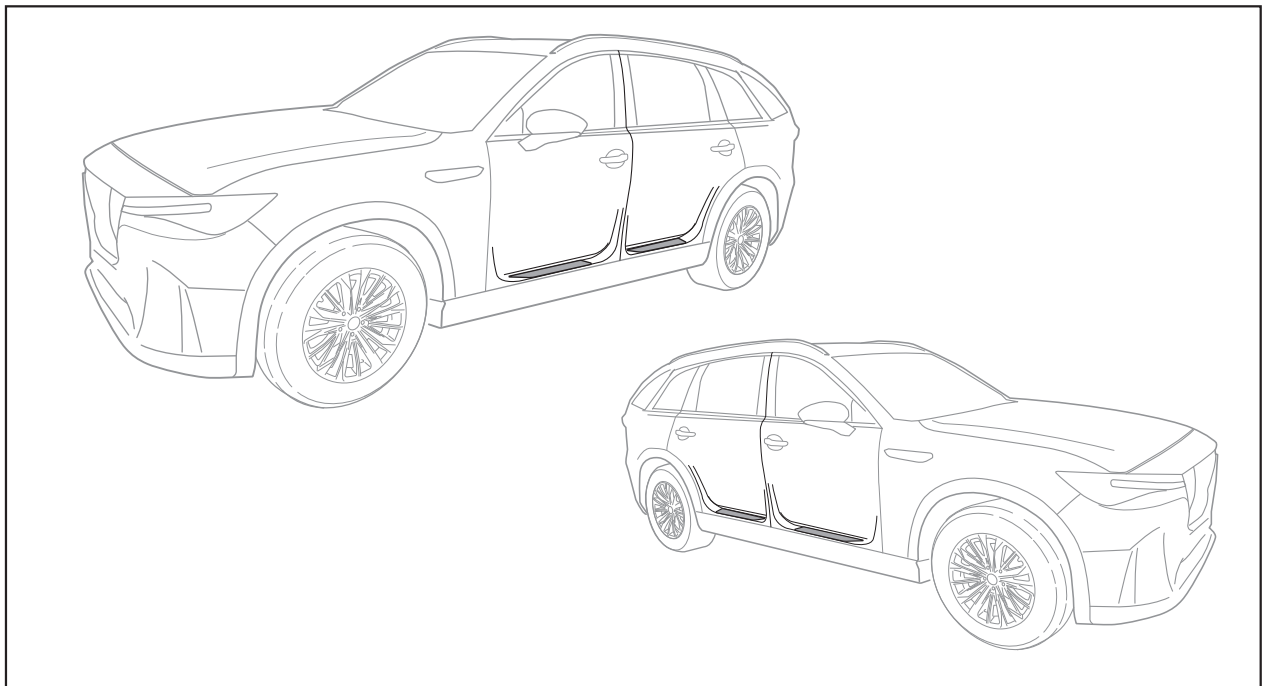

## 3. BEFORE INSTALLATION

### REQUIRED TOOLS







- Nylon Trim Removal Tool
- Masking Tape
- Paper Clip

### OTHER PREPARATIONS



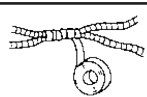

Prepare Vehicle:

- Vehicle and scuff plate should be at 13 degrees Celsius - 32 degrees Celsius (55 degrees Fahrenheit - 90 degrees Fahrenheit) for best results.
- Clean all dirt or other contaminants from surface.

#### WARNING

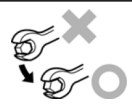
When the negative battery is connected during operation, may cause electric shock or other personal injuries. Disconnect the negative cable before /Installation.	Before performing any work, park the vehicle on level ground, apply the parking brake securely, and then block the wheels.	Be careful when handling drills and other sharp objects. If not handled properly, it could result in serious injury.	When connecting /dis- connecting connectors, grasp the connectors, not the wires. Otherwise a short, and an accident from poor contact or fire may occur.
			
Make sure the connector is securely pressed in until a click sound is heard. Otherwise, a fire or other accident may occur due to an open circuit or poor contact.	Secure the harness with the band (part included) so it doesn't dangle. If not, it may cause a short, accident, or fire.	Do not pull the harness with excessive force. Doing so can cause a breakage or a short-related accident, as well as an electrical short or fire.	
			

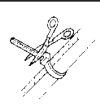
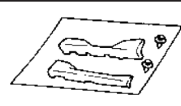
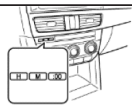
#### CAUTION

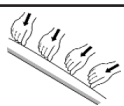
Using improper tools may cause damage and/or broken parts. Use the correct tool for the job.	Wrap protective tape around screw-drivers and fastener remover tools to prevent scratching the vehicle.	Excessive length of tie wrap may interfere with other parts and cause damage	Put the removed parts and the parts in the kit on the protective sheet to prevent scratches
			
When the negative battery cable is removed, the initial value or memory for the power windows, clock, i-stop, steering angle sensor reference point will be cleared. Perform re-initialization.	If there is dust, dirt or grease on the adhesion surface, the adhesive strength of the double-sided adhesive tape will splotch and adhesive power of the tape will be reduced. Wash and degrease the surface of the adhesion area before applying the double-sided adhesive tape. Be sure to wash interior and exterior parts using IPA (isopropyl alcohol).	If tape or a mount base is re-adhered, the adhesive strength will be weakened. Before adhering, accurately determine the adhesion position.	To assure sufficient adhesiveness of the double-sided adhesive tape, press the adhesive surface of the tape to the adhesion surface evenly. In particular, press sufficiently at the ends of the double-sided adhesive tape where the adhesion surface is curved.
			

#### ADVICE

Refer to the Workshop Manual for removal and installation of vehicle parts.



## 4. BEFORE INSTALLATION

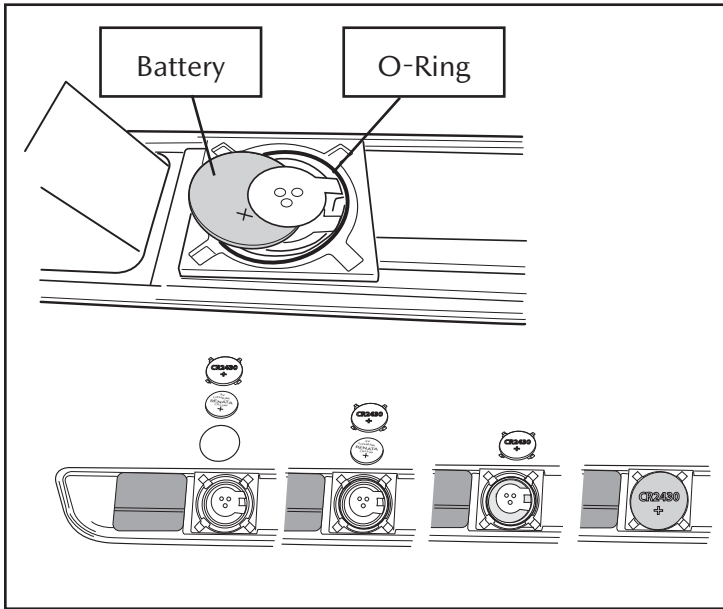

1. Install O-Ring, Batteries and Battery Caps from hardware kit as shown. Make sure the Battery is installed with the positive side placed up as shown.
2. Make sure O-ring is properly positioned prior to installing the Battery Caps.

## 5. VEHICLE PART REMOVAL, FRONT

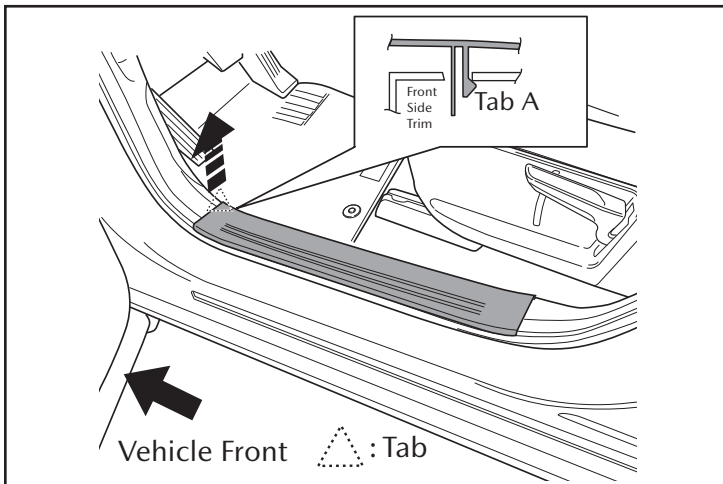

### Driver's Side Front Door

1. Use a nylon trim removal tool to carefully lift inside front bottom edge of scuff plate.
2. Pull upwards on the front edge of scuff plate and detach tab from lower trim.

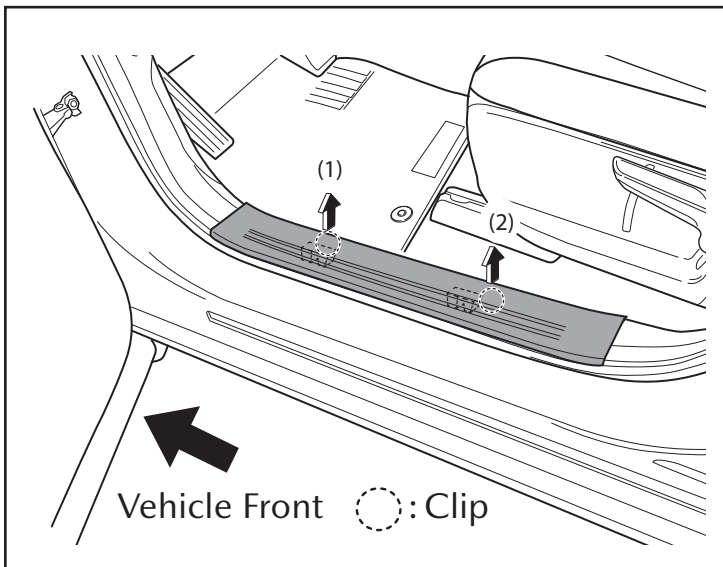

3. Carefully lift the scuff plate to detach clips at locations (1) and (2).

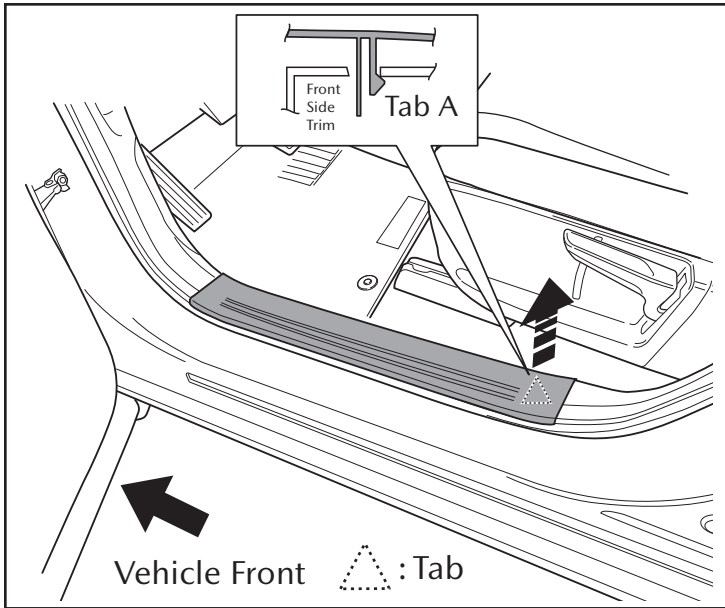

4. Use a nylon trim removal tool to carefully lift inside rear bottom edge of scuff plate.
5. Pull upwards on the rear edge of scuff plate and detach tab from lower trim.
6. Remove scuff plate and set aside.

## 6. PREPARATION FOR INSTALLATION

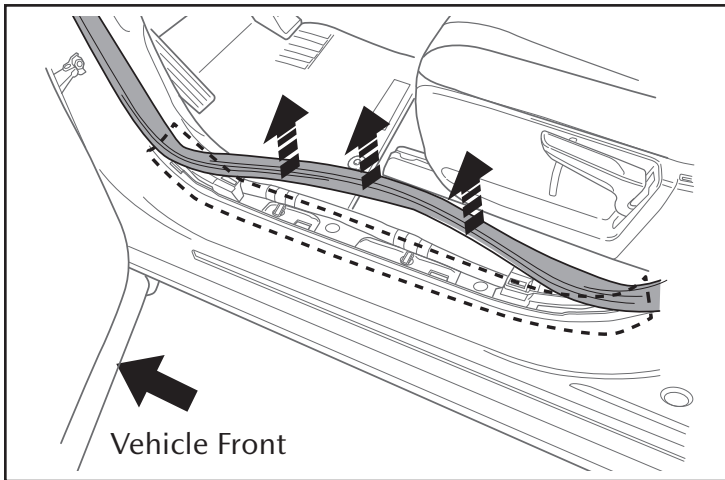

1. Lift up weather strip from the bottom portion of the door only.

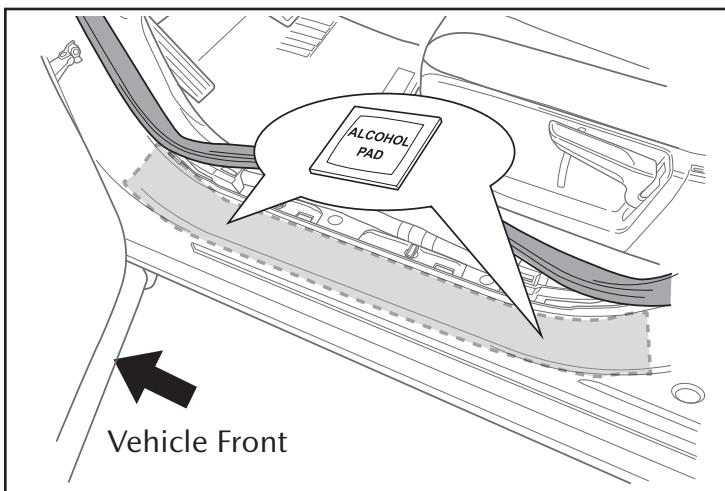

2. Using an Alcohol Pad, clean the area where the adhesive contacts the sheet metal.

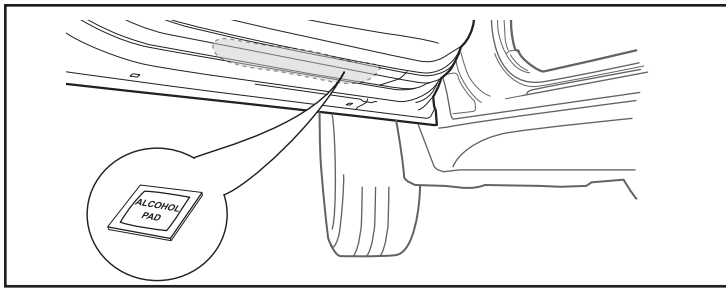

- Use the same Alcohol Pad to clean area under the door for where the Magnet is to be installed.

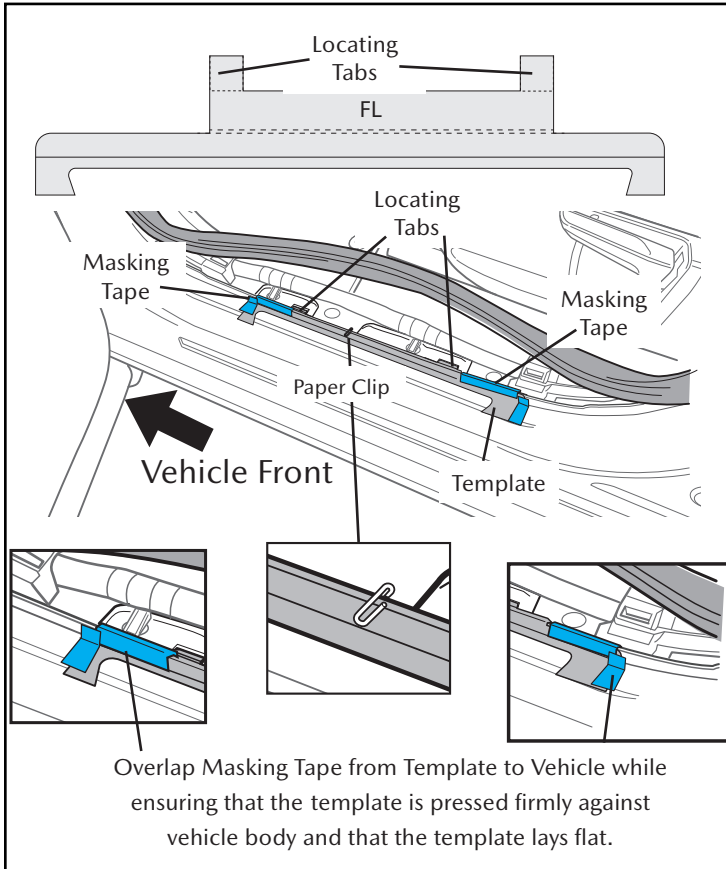

- Locate the Front Door Installation Template.

**NOTE**

- Refer to page 14 for template folding instructions.

**NOTE**

- Templates are marked either, FR,FL & RR, RL.  
Front Right=FR, Front Left=FL  
Rear Right=RR, Rear Left= RL

- Align Driver Side Front Installation Template onto door sill and fold locating tabs into vehicle slots.
- Tape down to hold in place while ensuring that the template is pressed firmly against vehicle body and that the template lays flat.
- Use paper clip to secure the center of template to vehicle body. This will allow the template to sit flat against vehicle body.

**NOTE**

- The tape needs to overlap the paper template and the vehicle body to ensure that template sits flat against vehicle.

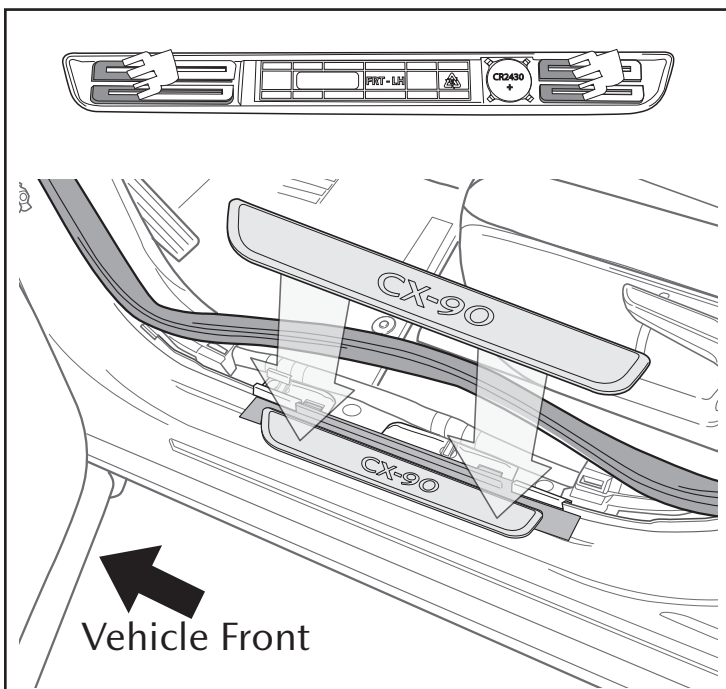

- Peel the liner from the tape and position Scuff Plate to the Template.

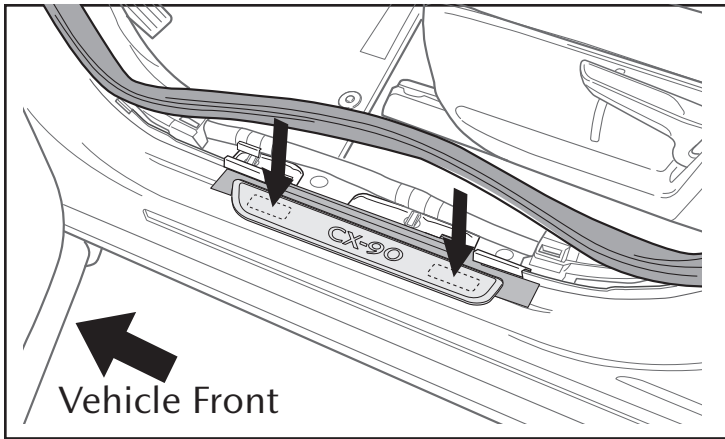

9. Press down on tape pad locations to apply firm pressure for approximately 15 seconds to ensure it attaches firmly and is secure.
10. Remove installation template.

**⚠ PRECAUTION**

DO NOT USE EXCESSIVE FORCE WHEN PRESSING DOWN ON THE SILL PLATE. DOING SO MAY RESULT IN COSMETIC DAMAGE TO PARTS.

## 7. INSTALL MAGNETS

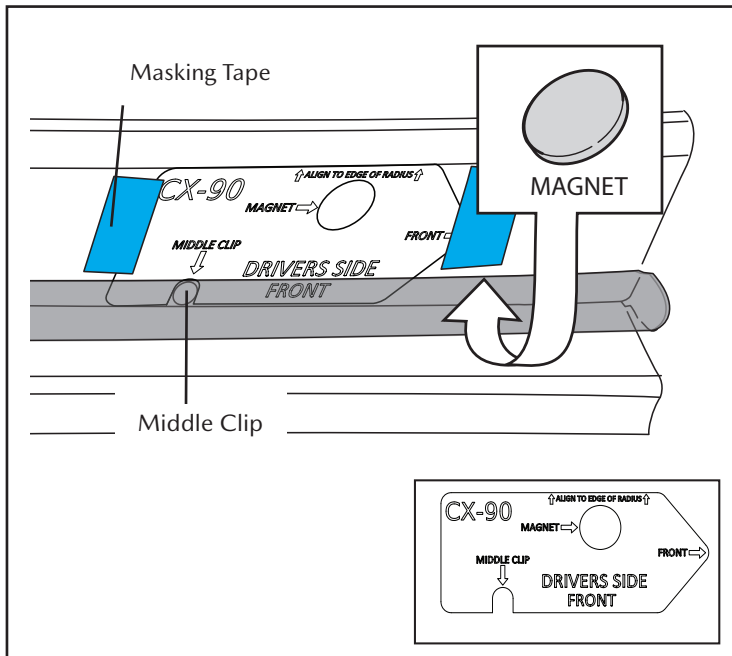

1. Locate the 3 clips holding the weather strip onto the underside of the front LH driver side door. The middle clip will be used to mount the Magnet Template. Ensuring the Template is pointing towards the front of the vehicle, align the notch on the Template labeled "Middle Clip" around the center clip in the vehicle. Ensure that the "Middle Clip" notch on the template does not slide behind the middle clip on the vehicle. The outer edge of the template aligns to the radius of the door edge.
2. Use two pieces of masking tape to secure the Magnet Template to the door.
3. The Magnet is then placed in the larger hole labeled "MAGNET".
4. Remove magnet template.

**NOTE**

- Confirm that the scuff plate illuminates before moving on to the next steps.

**⚠ PRECAUTION**

DO NOT CLOSE THE DOOR ON THE VEHICLE WEATHER STRIP

## 8. MAGNET TAPE

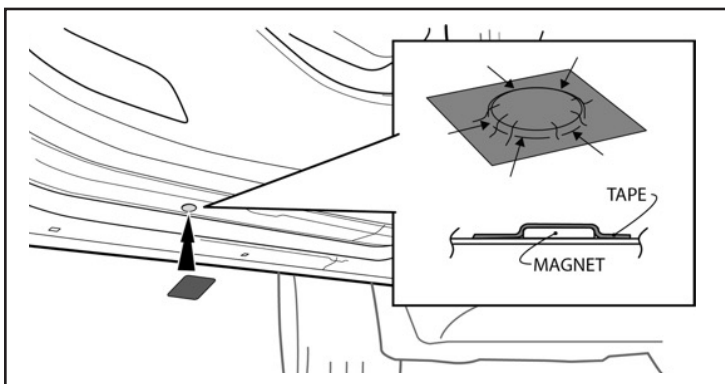

1. Remove the liner from one (1) Magnet Tape.
2. Position the Magnet Tape over the Magnet.
3. Press the Magnet Tape firmly to ensure proper adhesion to the door frame.
4. Apply pressure around the Magnet to reduce the air pockets in the Magnet Tape.
5. Close the driver's door. Open the driver's door, and confirm the Illuminated Scuff Plate illuminates.



## 9. VEHICLE PART REMOVAL, REAR

### Driver's Side Rear Door

1. Slide rear seat fully forward to access trim panel.

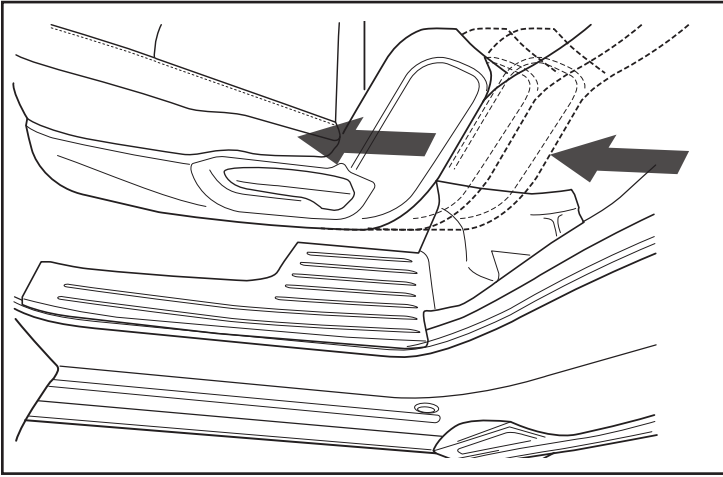

2. Use a nylon trim removal tool to carefully lift inside front bottom edge of rear scuff plate then lift to detach tabs at locations (1) - (7).

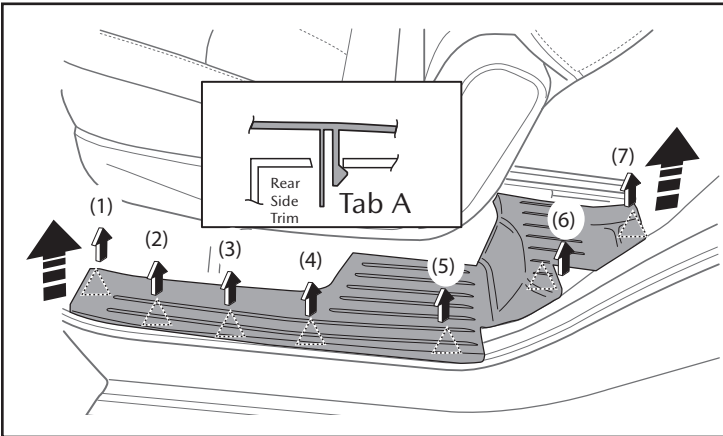

3. Use a nylon trim removal tool to carefully lift inside rear bottom edge of scuff plate and detach clips at locations (1), (2), & (3).  
4. Remove scuff plate and set aside.

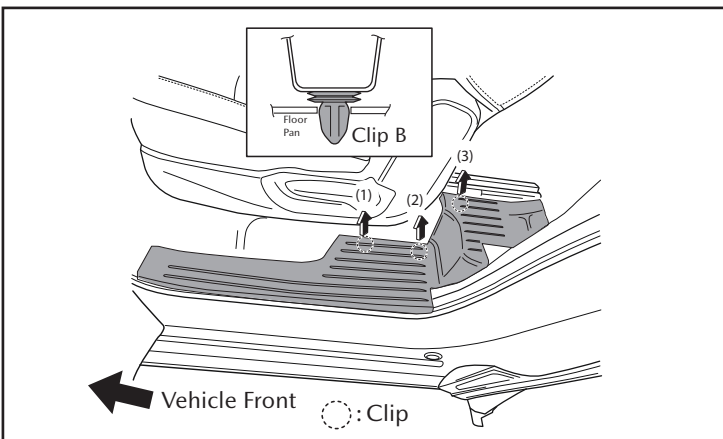



## 10 . PREPARATION FOR INSTALLATION

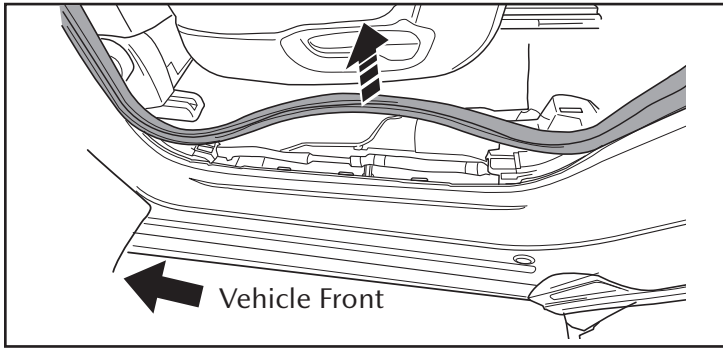

1. Lift up weather strip from the bottom portion of the door only.

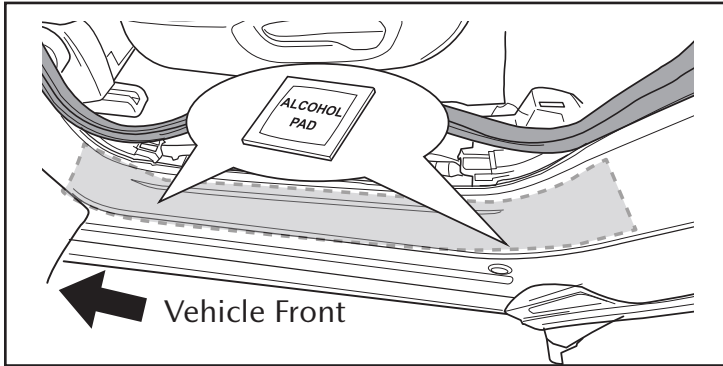

2. Using an Alcohol Pad, clean the area where the adhesive contacts the sheet metal.

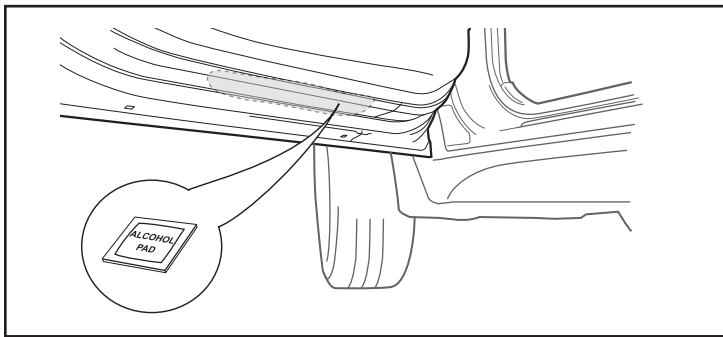

3. Use the same Alcohol Pad for under the door for where the Magnet is installed.

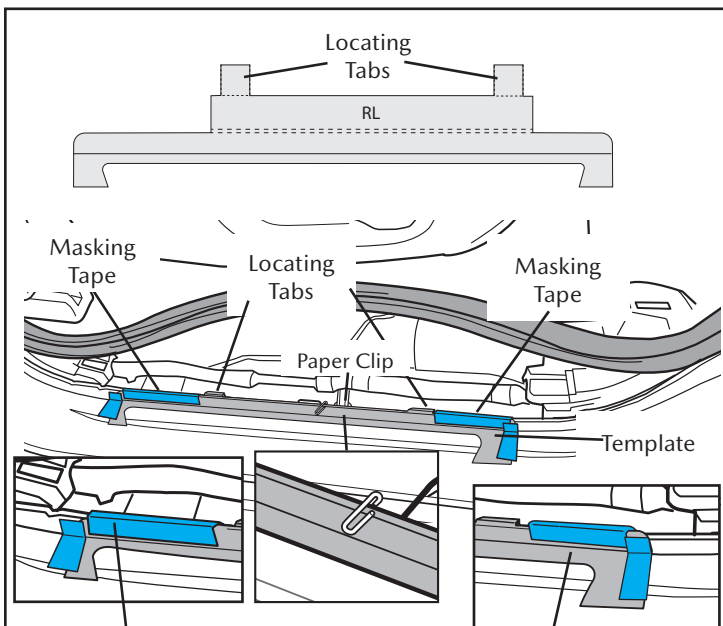

Overlap Masking Tape from Template to Vehicle while ensuring that the template is pressed firmly against vehicle body and that the template lays flat.

4. Locate the Rear Door Installation Template.

### NOTE

- Refer to page 14 for template folding instructions.

### NOTE

- Templates are marked either, FR,FL & RR, RL.  
Front Right=FR, Front Left=FL  
Rear Right=RR, Rear Left=RL

5. Align Driver Side Rear Installation Template onto door sill and fold locating tabs into vehicle slots.
6. Tape down to hold in place while ensuring that the template is pressed firmly against vehicle body and that the template lays flat.
7. Use paper clip to secure the center of template to vehicle body. This will allow the template to sit flat against vehicle body.

### NOTE

- The tape needs to overlap the paper template and the vehicle body to ensure that template sits flat against vehicle.

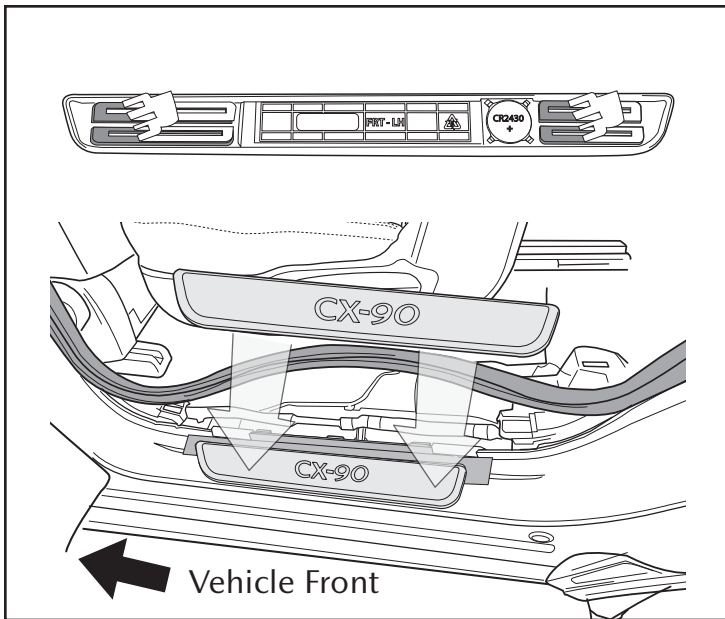

- Peel the liner from the tape and position Illuminated Scuff Plate to the Template.

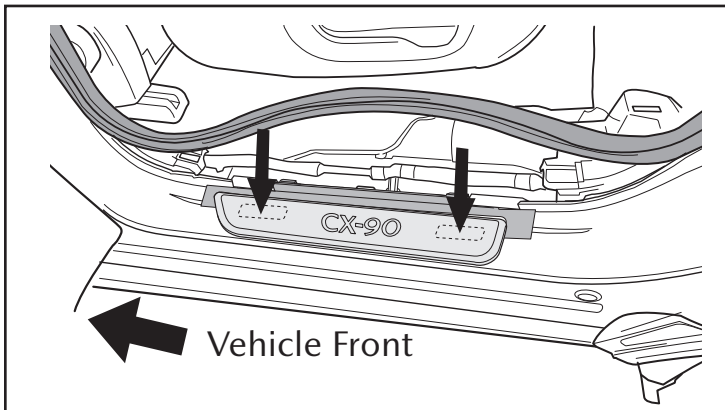

- Press down on tape pad locations to apply firm pressure for approximately 15 seconds to ensure it attaches firmly and is secure.
- Remove installation template.



**CAUTION**

DO NOT USE EXCESSIVE FORCE WHEN PRESSING DOWN ON THE SILL PLATE. DOING SO MAY RESULT IN COSMETIC DAMAGE TO PARTS.

**11. INSTALL MAGNETS**

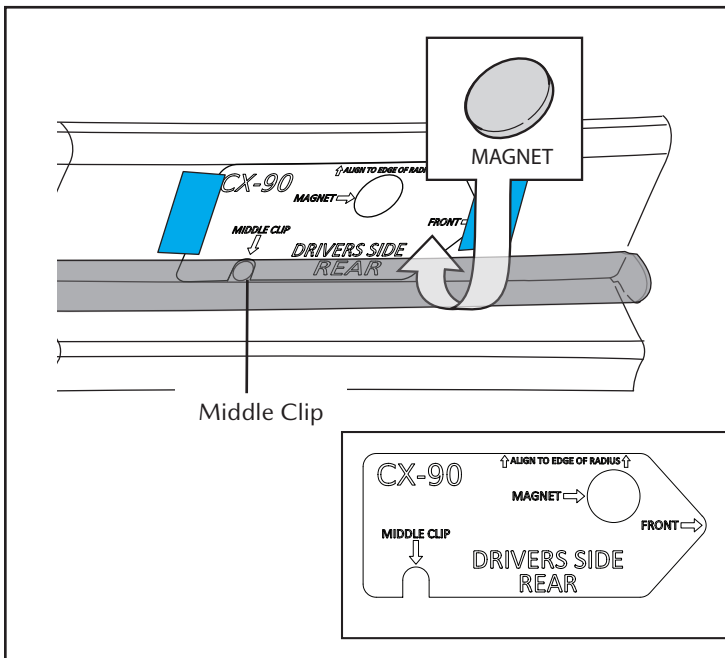

- Locate the 3 clips holding the weather strip onto the underside of the rear LH driver side door. The middle clip will be used to mount the Magnet Template. Ensuring the Template is pointing towards the front of the vehicle, align the notch on the Template labeled "Middle Clip" around the center clip in the vehicle. Ensure that the "Middle Clip" notch on the template does not slide behind the middle clip on the vehicle. The outer edge of the template aligns to the radius of the door edge.
- Use two pieces of masking tape to secure the Magnet Template to the door.
- The Magnet is then placed in the larger hole labeled "MAGNET".
- Remove magnet template.

**NOTE**

- Confirm that the scuff plate illuminates before moving on to the next steps.



**CAUTION**

DO NOT CLOSE THE DOOR ON THE VEHICLE WEATHER STRIP

## 12. MAGNET TAPE

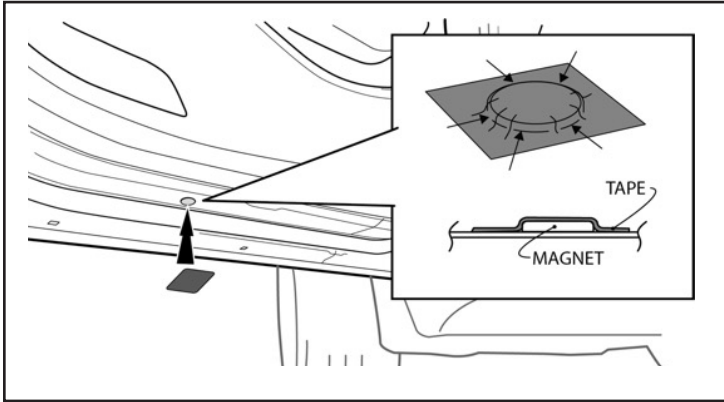

1. Remove the liner from one (1) Magnet Tape.
2. Position the Magnet Tape over the Magnet.
3. Press the Magnet Tape firmly to ensure proper adhesion to the door frame.
4. Apply pressure around the Magnet to reduce the air pockets in the Magnet Tape.
5. Close the rear door. Open the rear door, and confirm the Illuminated Scuff Plate illuminates.

## 13. RH PASSENGER SIDE INSTALLATION

1. Repeat steps 5-12 for the RH Passenger Side installations of the front and rear Illuminated Scuff Plates.

## 14. REASSEMBLE VEHICLE

1. Reinstall vehicle components in the reverse order that they were removed.

## 15. BATTERY REPLACEMENT

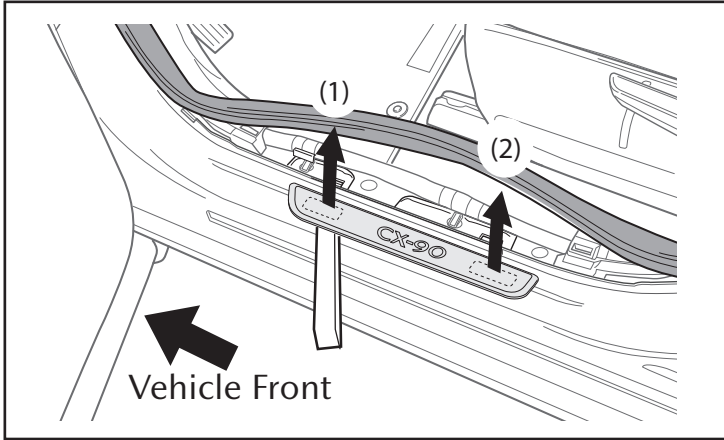

1. Using a nylon trim removal tool, carefully lift up on the Illuminated Scuff Plate Clip locations to remove.

### ⚠ CAUTION

- Do not lift up the scuff plate from the outside edge. This will result in damage to the scuff plate.

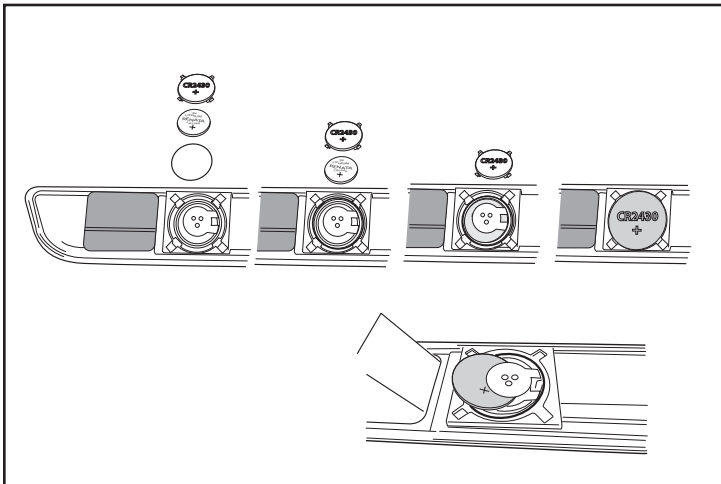

2. Turn the scuff plate upside-down, and remove the battery cover.
3. Take the battery out and replace with a fresh battery.
4. Reinstall the cover.

### NOTE

- Batteries: Lithium CR 2430 batteries/1 per scuff plate. (Total 4 batteries per vehicle)

# 16. INSTALLATION INSPECTION SHEET

[To be used by installation workshop]

Mazda CX-90	Illuminated Door Scuff Plates
	All models

Inspect the installed parts per the items listed below

INSPECTION ITEMS	OK	NG	COMMENTS
Dings/Dents/ Creases/Indentations			
Scratches/ Stains			
Tape Residue/ Fingerprints			
Illumination (4 Plates)			
Tape Applied Over Magnets			

Date		(year/month/day)			
VIN No.					
Approved		Checked		Prepared	

\*Retention period of this sheet: 12 months

## Illuminated Door Scuff Plate Template Folding

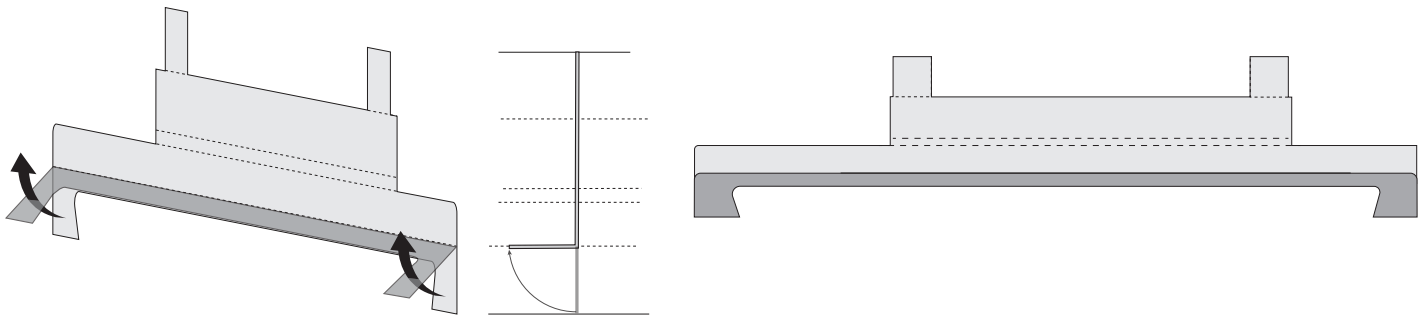

Step 1

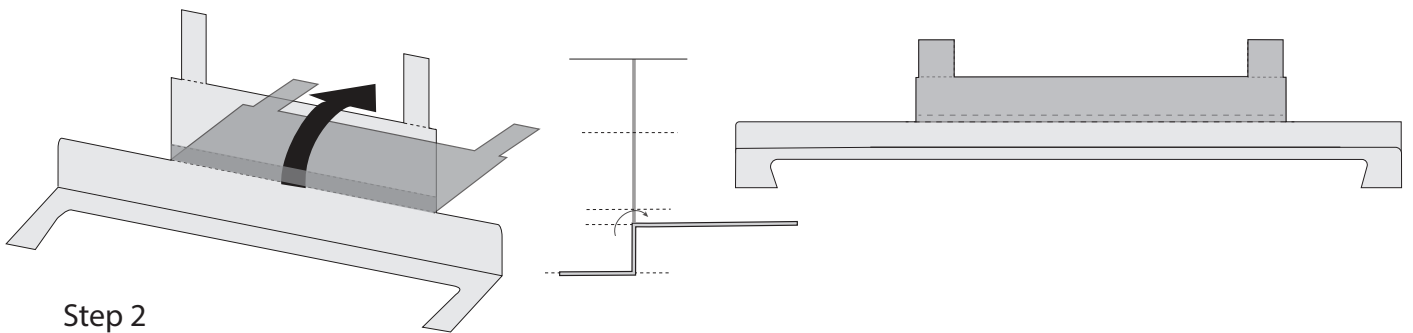

Step 2

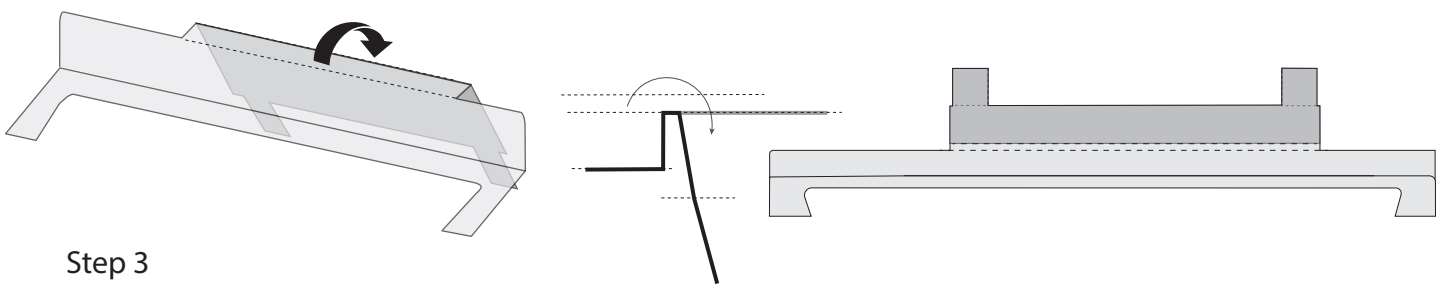

Step 3

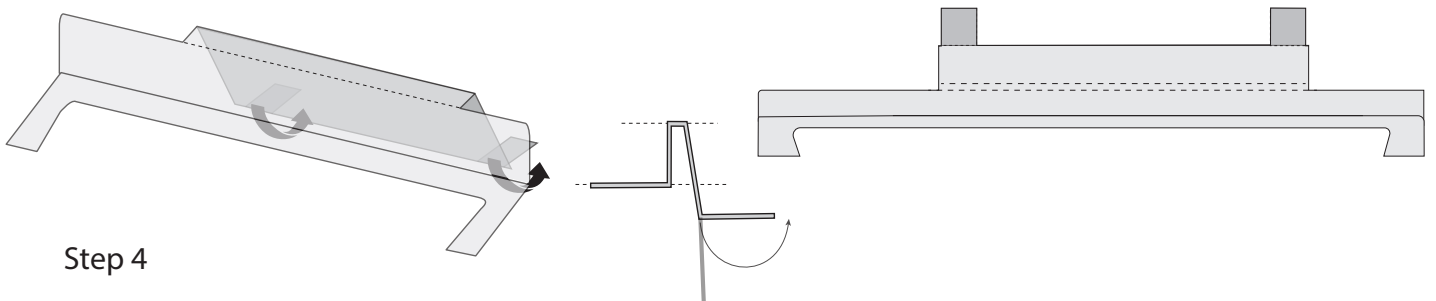

Step 4