

GENUINE SIDE ROCKER GARNISH

INSTALLATION AND USER'S INSTRUCTIONS

Thank you for purchasing a Genuine Mazda Accessory

Before removal and installation, please thoroughly read these instructions.

For your safety, please read and contents of this booklet to properly install and use the Side Rocker Garnish kit. Keep these instructions with your vehicle for future reference.

- There are several WARNING and CAUTION sections in this booklet concerning safety when installing the Side Rocker Garnish. Always read and follow the instructions in order to prevent injuries, accidents, and possible damage to the vehicle.



Indicates a situation in which serious injury or death could result if the warning is ignored.



Indicates a situation in which bodily injury or damage to the vehicle could result if the caution is ignored.

- Do not modify the Side Rocker Garnish.
- Do not install the Side Rocker Garnish in any way other than described in the following instructions.
- If in doubt, please contact your Mazda dealer to install the accessory in order to prevent errors in installation.
- If you have any questions about the use of the accessory, ask your Mazda dealer for proper advice before using it.
- Mazda and its suppliers are not responsible for injuries, accidents, and damage to persons and property that arises from the failure of the dealer or installer to follow these instructions.
- To ensure safety and reliability of the work, installation, removal and disposal work must be carried out by an Authorized Mazda Dealership.
- Be careful not to lose removed parts, and be sure that they are kept free of dirt, scratches, or damage.

PART NAME: SIDE ROCKER GARNISH
PART NUMBERS: VA40V3100 /VAS0V3100
VEHICLES: MAZDA CX-50

NOTE

To the dealer

- Please turn over these instructions to the customer after installation.
- Keep these instructions after installation. The instructions may be necessary for installing other optional parts or removal of this accessory.
- Should the vehicle or this accessory be resold, always transfer these instructions to the next owner.

INSTALLATION INSTRUCTIONS

PART NUMBERS
VA40V3100/VAS0V3100

SIDE ROCKER GARNISH

APPLICABLE MODEL
2023> Mazda CX-50

PACKAGE CONTENTS



PANEL CLIP X8



CLIP X2



ALCOHOL PAD X2

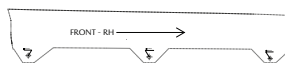
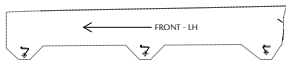

ALIGNMENT
TEMPLATES

TOOLS REQUIRED



50% ISOPROPYL ALCOHOL
RESIDUE FREE CLEANER
SOFT LINT FREE CLOTH



MASKING TAPE



ELECTRIC DRILL



DRILL BITS: 3MM/8MM/9MM
(1/8TH/17/64TH - 9/32ND)



RUBBER ROLLER



SCISSORS



CAUTION:

MAKE SURE TO FOLLOW INSTRUCTIONS CAREFULLY TO
ENSURE CORRECT INSTALLATION

BEFORE INSTALLATION:

1. Read entire Installation Instruction before proceeding.
2. Vehicle must be at room temperature. this is recommended to allow the tape to adhere in temperatures over 50° for at least 30 minutes.
3. Clean the area around the installation area prior to installation using a mixture of 50/50 alcohol and water.
4. Allow vehicle to dry completely before attempting installation.

1. Prepare Vehicle Driver Side:

- A. Clean the tape attachment areas with soap and water.
- B. Using the alcohol prep pad provided thoroughly wipe the area shown and allow to dry.

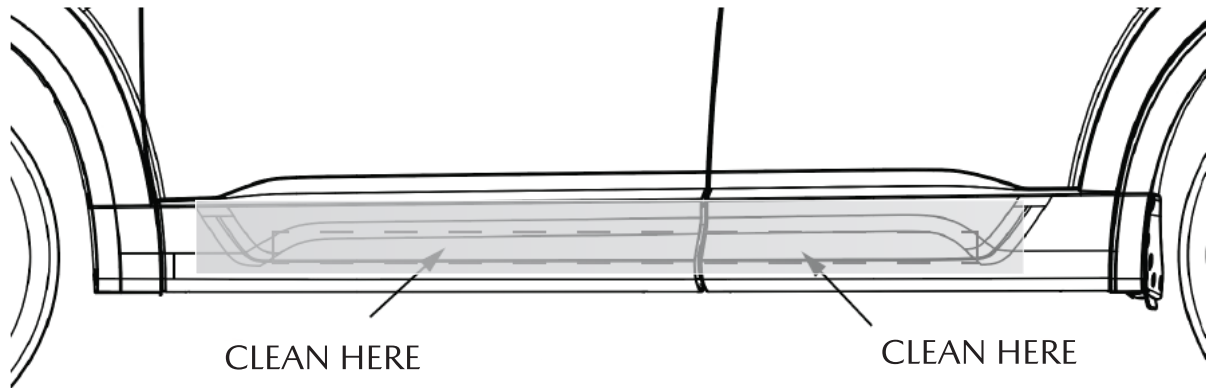

2. Position Alignment Templates

- A. Cut out the templates following the dotted lines.
- B. Place the templates into position making sure to carefully align to the top edge of the door cladding and the edge of the cladding near the door gap.
- C. Smooth the paper template down the door cladding making sure no wrinkles are in template.
- D. Tape into place.

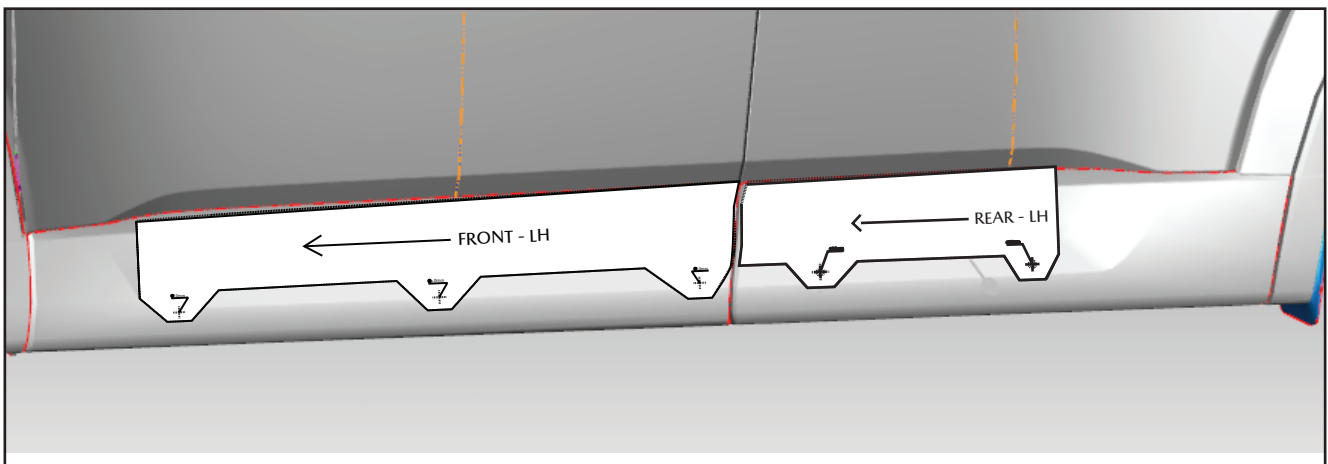

3. Drill Mounting Holes

- A. Wrap drill bit with tape as shown.
- B. Locate the 5 holes on the alignment templates and using centerpunch mark the hole locations.
- C. Remove templates and discard.
- D. Pre-drill holes using a 3.0mm drill bit.
- E. Drill holes using the correct drill bits as identified below.
- F. Remove any burrs or loose plastic.

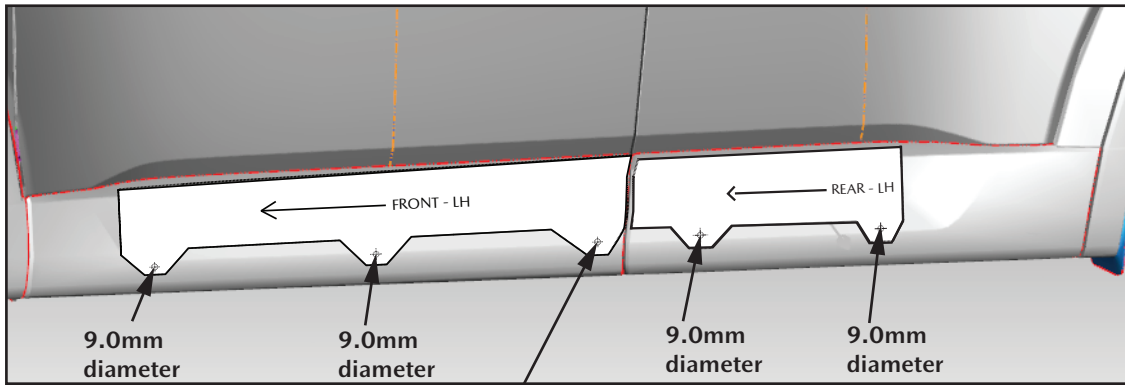
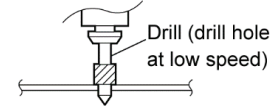
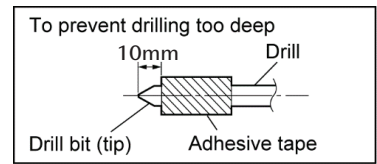

 **CAUTION** Drill this hole with 8mm drill only

4. Prepare the Side Rocker Garnish

- A. Slide the plastic clips into the clip carriers (NOTE position of clips should be centered and able to move back and forth)
- B. Peel back the backing tape liner strips approximately 50 mm or 2 inches as shown on page 5.
- C. Fully remove the two backing tape liners from each end of the part and do not touch exposed surface of the backing tape.

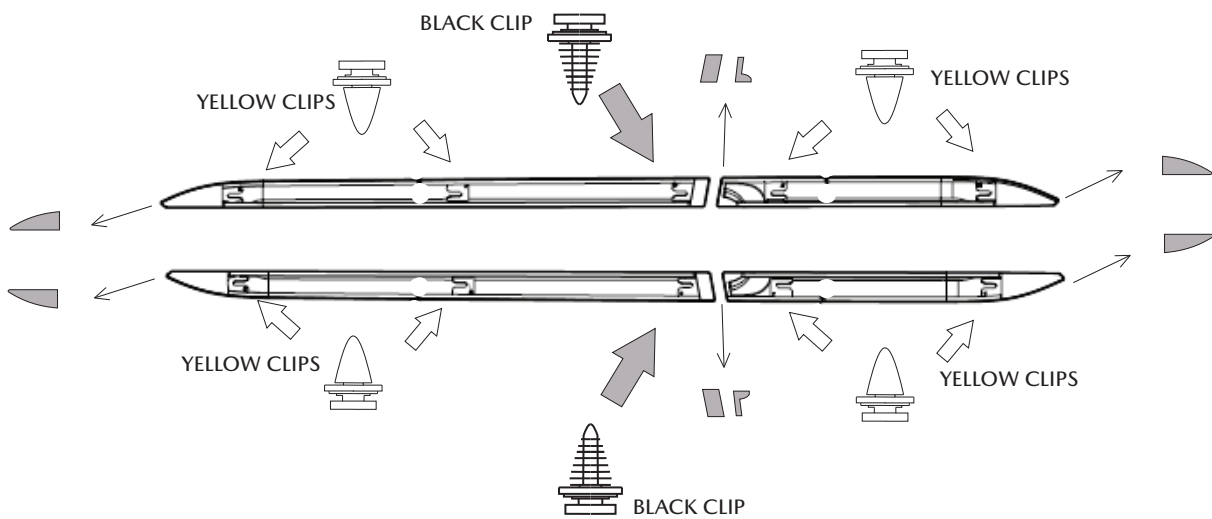

5. Install Side Rocker Garnish

- A. Carefully install the front rocker garnish using the clips to align to the holes on the front door cladding. Avoid touching exposed tape. Please follow the placement tolerance as shown below before applying pressure to the side rocker garnish.
- B. Peel the upper backing tape first.
- C. When all the liners are removed, apply light pressure along the upper edge starting from the middle of the side rocker garnish.
- D. Using the rubber roller, starting from the center out, press down the perimeter of the rocker garnish to ensure proper bond of adhesive. Use with caution to ensure the roller does not scratch vehicle or the side rocker garnish.
- E. Inspect for proper adhesion and placement. Verify the part is not loose and there are no gaps larger than .50mm around perimeter of the part
- F. Repeat for the rear door also ensuring that the front and rear Side Rocker Garnish are level and aligned with the tangency of the door cladding as shown below.

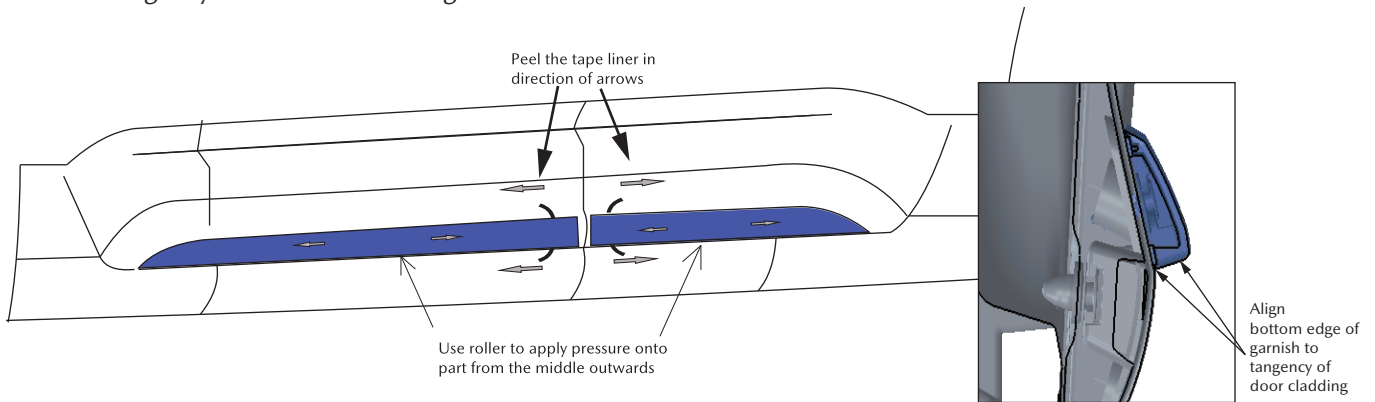

(Placement tolerance)

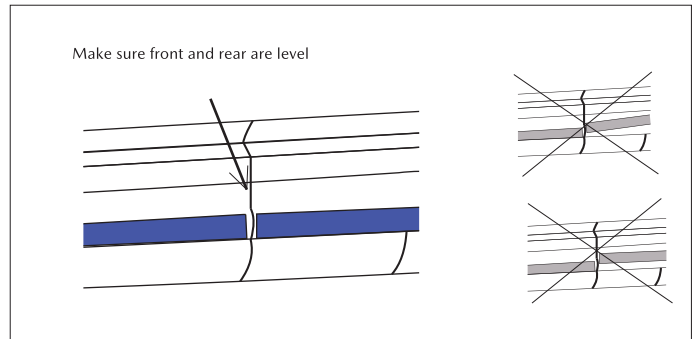
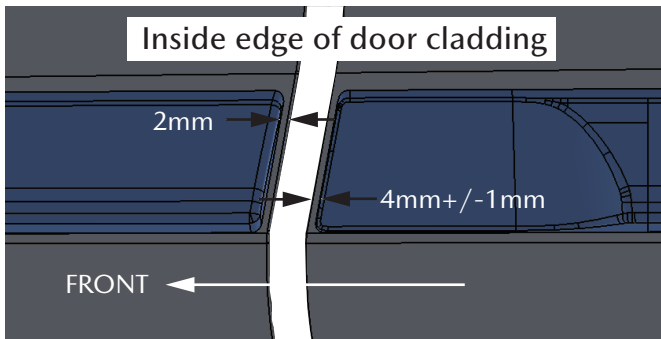

5. Install Side Rocker Garnish- Passenger Side

- A. Repeat Steps 1-5 for passenger side installation

Inspection intended with Side Rocker Garnish installed

Inspection Part	Inspection Items (O)			
	Clearance and Fit	Scratches and Dirt	Installation Gaps	Open and close doors
Side Rocker Garnish are straight and aligned with lower edge of door cladding	--	O	O	--
Side Rocker Garnish is placed within stated tolerance to edge of door cladding	O	O	--	O

O: Applicable

Date:
Vehicle:
VIN:

Approved		Checked		Person In Charge	
----------	--	---------	--	------------------	--